

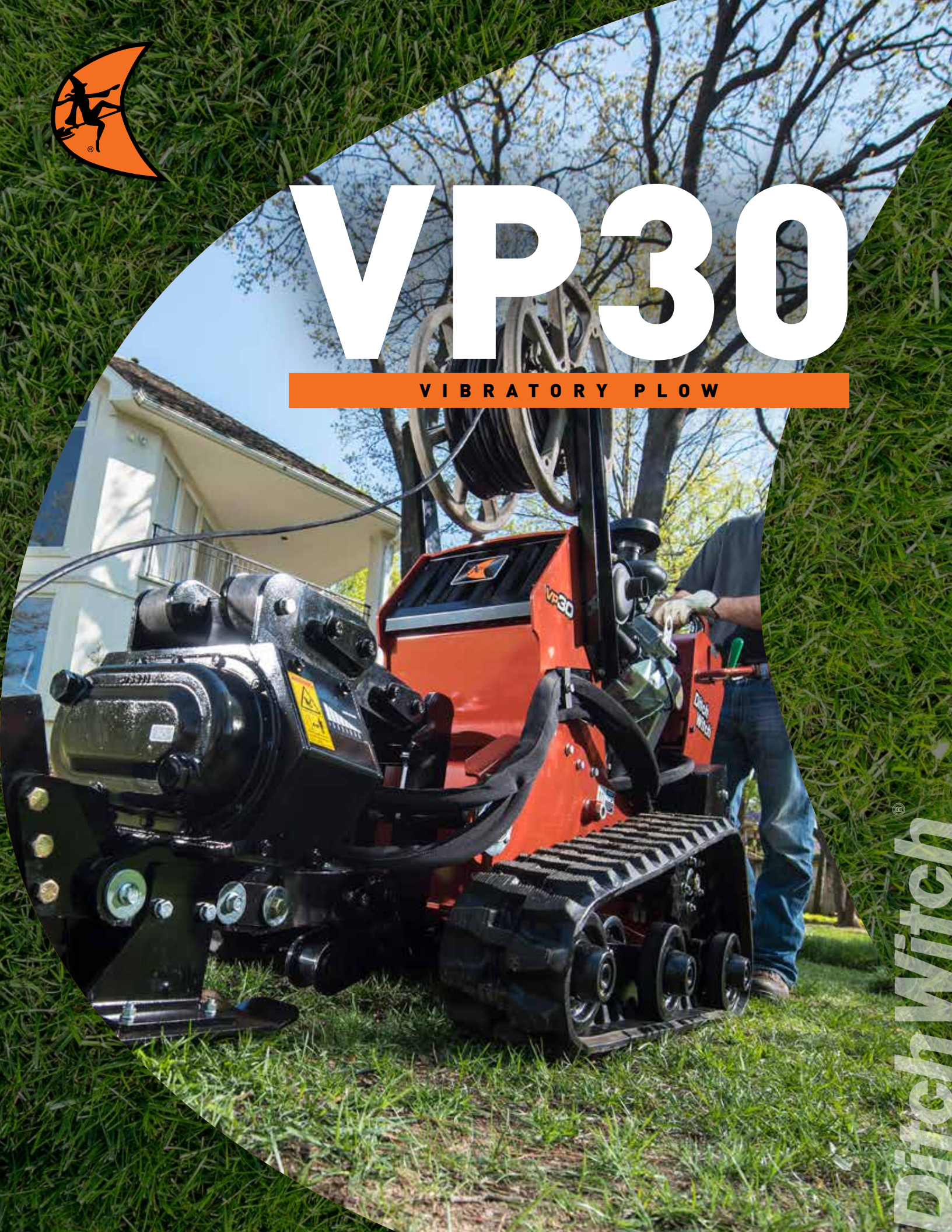

# VP30

VIBRATORY PLOW



Ditch Witch®

# VP30

The VP30 has no daily grease zerks—a Ditch Witch exclusive—so daily maintenance is quick and easy.

Powered by a 31-hp (23-kW) Briggs and Stratton® engine, making the VP30 the most powerful machine in its class.

Hydrostatic steering and easy-touch controls increase machine responsiveness and reduce operator fatigue.

An industry-first variable flow control helps you control the flow to the shaker box and adjust ground drive speed for varying ground conditions, improving overall productivity.

Exceptionally low ground pressure of 4.1 psi (0.28 bar) creates minimal disruption to residential lawns.

Uses greaseless, sealed bearings for extended track assembly life.

Standard outboard bearing support helps stabilize the unit's shaker box for reliable and efficient performance on every job.

Equipped with two new adjustable blades—the pull blade and feed blade—which can be adjusted between 6-in (152.4 mm) and 12-in (304.8 mm) to meet fiber installation-depth requirements in various areas.



- 1 An industry-first variable flow control helps you control the flow to the shaker box and adjust ground drive speed for varying ground conditions, improving overall productivity.
- 2 Hydrostatic steering and easy-touch controls increase machine responsiveness and reduce operator fatigue.
- 3
- 4 Powered by a 31-hp (23-kW) Briggs and Stratton® engine, making the VP30 the most powerful machine in its class.
- 5 Construction-grade, compact design allows for better maneuverability on tight, residential jobsites.
- 6 Equipped with two new adjustable blades—the pull blade and feed blade—which can be adjusted between 6-in (152.4 mm) and 12-in (304.8 mm) to meet fiber installation-depth requirements in various areas.
- 7 Standard outboard bearing support helps stabilize the unit's shaker box for reliable and efficient performance on every job.
- 8 Uses greaseless, sealed bearings for extended track assembly life.
- 9 Exceptionally low ground pressure of 4.1 psi (0.28 bar) creates minimal disruption to residential lawns.

# VP30 VIBRATORY PLOW SPECIFICATIONS

## DIMENSIONS (STD)

	U.S.	METRIC
Reel carrier diameter, max (A)	20 in	508 mm
Plow depth, max (B)	12 in	305 mm
Ground clearance w/plow in stow, min (C)	6 in	152 mm
Machine height (H)	48 in	1.22 m
Plow blade height in stow (H1)	47 in	1.19 m
Height w/max reel diameter (H2)	59 in	1.50 m
Machine length, max, w/blade (L)	91 in	2.31 m
Track length (L1)	35 in	890 mm
Machine width (W)	35 in	890 mm
Product wheel width, max (W1)	14 in	355 mm

## OPERATION

Ground drive speed, max		
Forward	1.41 mph	2.27 km/h
Reverse	1.43 mph	2.30 km/h
Ground pressure	4.1 psi	0.28 bar
Approach angle w/adjustable feed blade	35°	
Machine weight	1,993 lb	904 kg

## POWER

Engine	Briggs & Stratton® Vanguard™	
Manufacturer's gross power rating (per SAE J1940)	31 hp	23.1 kW
Fuel	Gasoline	
Cooling medium	Air	
Number of cylinders	2	
Displacement	54.7 in³	0.90 L
Bore	3.37 in	85.5 mm
Stroke	3.07 in	78 mm
Rated speed	3,600 rpm	

## HYDRAULIC SYSTEM

	U.S.	METRIC
Auxiliary circuit, double gear pump		
Flow rate (pump #1)	13.25 gpm	60.3 l/min
Flow rate (pump #2)	3.74 gpm	17 l/min
Pressure	3,000 psi	207 bar
Ground drive, dual hydrostatic pumps		
Pressure	2,500 psi	172 bar

## FLUID CAPACITIES

Fuel tank capacity	6.2 gal	23.5 L
Hydraulic reservoir	11.5 gal	43.5 L
Engine oil w/filter	2.3 qt	0.95 L

Specifications are general and subject to change without notice. If exact measurements are required, equipment should be weighed and measured. Due to selected options, delivered equipment may not necessarily match that shown.

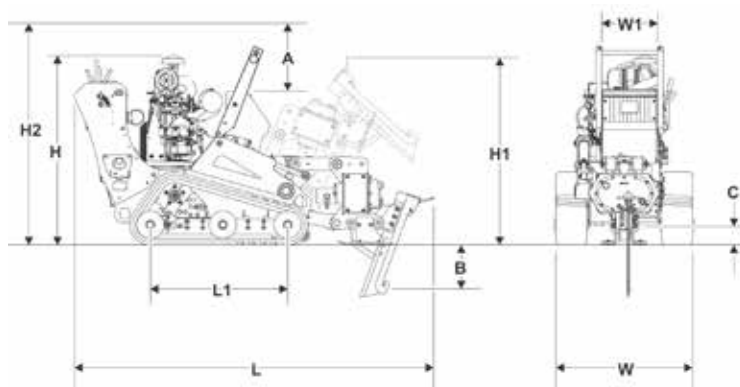

## DEALER SERVICE & SUPPORT



Every Ditch Witch machine comes backed by our global dealer network. Our factory-trained professionals at each location are there to offer the unrivaled support and service to keep you working.

